

HOT-GAS GENERATOR

1 The burner fires into the hot-gas generator and intensively heats the circulating air using counterflow action.

2 Indirect heating of the recycling material in the recycling drum using hot air - no flame contact

3 In the recycling drum, the recycling material is gently heated to the processing temperature in the counterflow.

4 Up to 100 % recycling content

5 Low exhaust gas temperature of only 100 °C

6 The recycling material heated to processing temperature can be buffered in the recycling silos or processed directly.

7 Optimum processing temperature of 160 °C

- Circulating air
- Hot gas
- Exhaust air
- Recycling material



CLEAN PERFORMANCE.

RECYCLING DRUM USING COUNTERFLOW ACTION WITH HOT-GAS GENERATOR

CLEVER RECYCLING SOLUTION

Efficient and environmentally friendly

Providing asphalt in the required quality and quantity at the right time is already a challenge that requires perfectly coordinated plant components. When maximum recycling content in asphalt production with minimum emissions are added to the equation, the BENNINGHOVEN hot-gas generator becomes indispensable.

The leading, patented recycling technology from BENNINGHOVEN allows plant owners to produce asphaltic mixtures from 100 % reclaimed asphalt. At the same time, the asphalt mixing plant meets the stringent official limits for air quality control, including the German TA-Luft regulation.

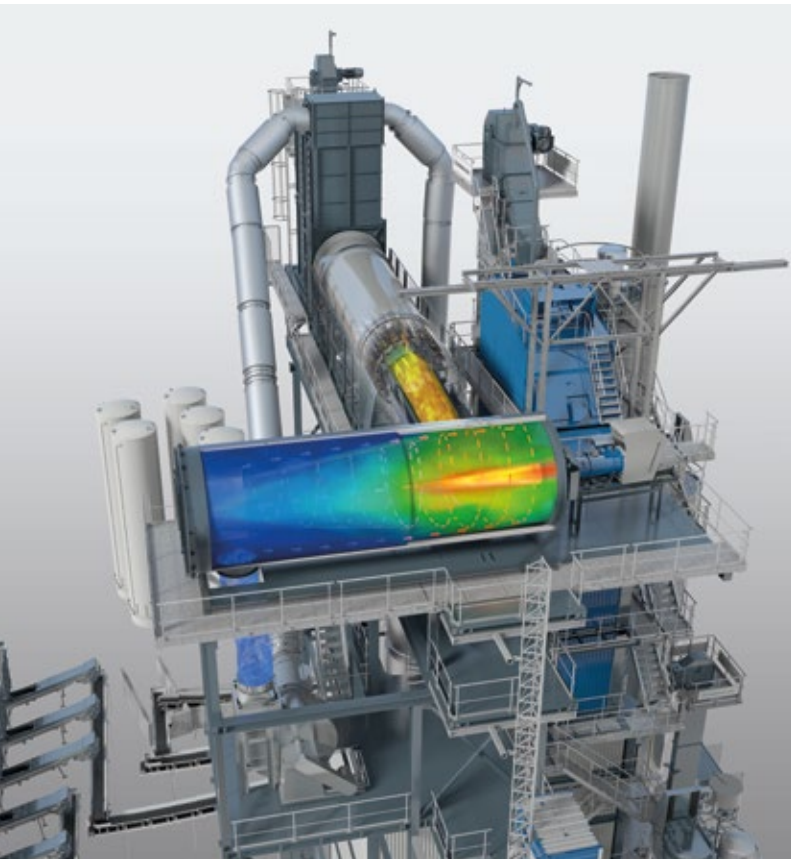

01 Clever process solution

- > The recycling material is heated to the optimum processing temperature of 160 °C.
- > The emissions are kept in the standard range and the contained bitumen is not burned.

While the recycling material containing bitumen would “burn” with direct firing or undergo an adverse change to its properties, the hot-gas generator only heats it indirectly, gently bringing it up to its optimum application temperature.

At the same time, the process lowers the emissions - for example by burning most of the total carbon contained in the exhaust flow.

The hot-gas generator technology allows fresh asphaltic mixtures to consist of 100 % reclaimed asphalt.

BENNINGHOVEN offers integration of the hot feed system as a new system or as a retrofit solution for existing asphalt mixing plants.

The result - crucial advantages:

- > High recycling content of 100 %
- > Lower emissions , $C_{tot} < 50\text{mg}/\text{m}^3$
- > Better energy balance of the plant
- > Lower strain on the filter unit
- > Reduced bitumen costs
- > More sustainable and more efficient asphalt production
- > Saves CO_2



02 Hot feed system

The main components of the hot feed system are coordinated to optimise the process.

- > RAP chute (self cleaning)
- > Recycling drum
- > Burner
- > Hot-gas generator
- > Extraction hood
- > Transitions / knife valves are heated, preventing adhesions at transition areas



03 Hot-gas generator

The hot-gas generator essentially consists of a large cylindrical body with a highly temperature-resistant special insulation on the inside. Inside, there is the heat-resistant burner cone and the combustion chamber with swirl vane. The opening for the burner on the face side is equipped with a pneumatically actuated heat protection door. A large maintenance access in combination with the key transfer system ensures maximum safety and ease of maintenance.

High recycling content along with low emissions can only be achieved using the principle of counterflow action in combination with a hot-gas generator. Why? With the hot-gas generator technology, only a small quantity of C_{tot} can be generated because the recycling material is heated to 160 °C with high efficiency and has no contact with the burner flame. Degasification of bitumen is therefore minimised. Any generated VOC concentration are mostly returned to the hot-gas generator with the circulating air and burned there.

The burner in the hot-gas generator also uses the counterflow action to heat the circulating air to the desired hot gas temperature. The large flame chamber offers enough space for complete combustion, ensuring low carbon monoxide emissions (CO).

Advantages of the design:

- > No direct heat transfer through radiation
- > No direct contact with the outer shell of the hot-gas generator
- > Therefore no expansion of the hot-gas generator
- > Sealing reduces the false air content
- > Result: longer service life

04 Recycling drum

- > Recycling material flows against the heat flow
- > Longer active dwell time of the RAP material in the drum and gentle indirect heating
- > Better heat transfer with optimised material veil (100 % closed material curtain) in the drum
- > Homogeneous heating of the drum with new generation of internal drum parts (patented)
- > Less material accumulation/adhesions and self cleaning effect

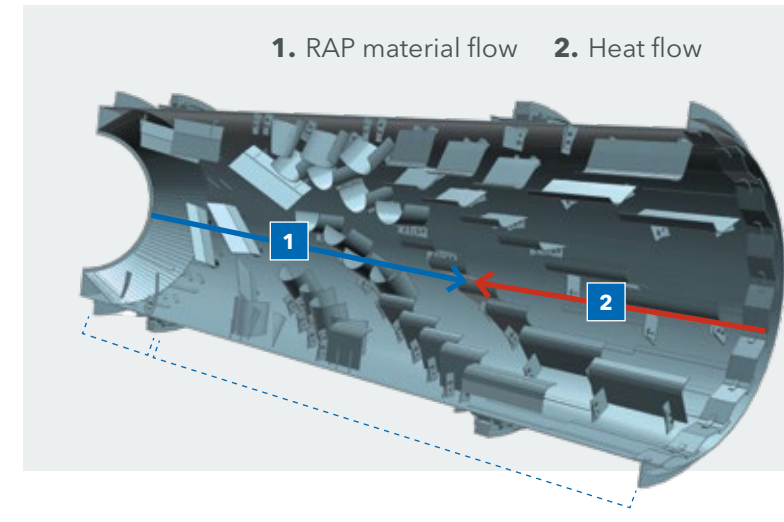

05 Extraction hood

- > The extraction hood acts as a separator (fine particles)
- > The exhaust flow can be calmed with the large extraction hood so that particles from the exhaust gas flow can settle.
- > High level of separation so that fine particles cannot enter the exhaust gas channels but rather settle in the collection hull (no risk of the circulating air and exhaust air pipes clogging)

Ideal for users and the environment

06 Low emissions

- > Compliance with stringent legal emissions limits (e.g. in Germany: guaranteed compliance with the limits of the TA-Luft regulation in continuous operation with appropriate measurements)
- > Permissible ½-h average threshold values as per the official air quality requirements:
 - Cto < 50 mg/Nm³,
 - CO < 500 mg/m³
 - NOx < 350 mg/m³
- > Clever air flow on the plant - emissions from the mixer and the skip track can be added to the hot recycling system and burned. (See diagram, item 02.)

07 Energy optimisation - to protect the plant and the environment

- > The mineral does not have to be overheated.
- > **Gentle on the material**
- > **Gentle on the plant (no hydraulic shocks)**
- > **Energy-optimised** - e.g. with a frequency-controlled, closed system for circulating air and exhaust air
- > Lower load on the dust collection system (filter bags) due to lower fine content from the recycling process
- > Adjustable exhaust gas temperature level, just above the dew point
- > Reduced emissions, which degasify at below 160 °C during heating of recycling material or aggregates

08 Recipe generator

- > System-relevant software expansion for dynamic generation of recipes with variable recycling content
- > Advantage when running a high recycling content
- > No production interruption when changing the RAP feed rate
- > No recipe change necessary
- > Continuous asphalt quality



09 Easy maintenance thanks to excellent accessibility

- > Large, ergonomic maintenance access points, service and inspection openings
- > Movable burner - inspection of the burner head
- > Partial replacement of segments of the RAP chute including ceramic coating
- > Fixed slinging points for abseiling
- > Extraction hood with walk-on options
- > **Key transfer system for increased safety:**
 - Key-operated mechanical system
 - Based on the premise that a key cannot be in two places at the same time
 - The key can only be removed in the safe state if there are no hazards present.
 - Highly intuitive safety concept
 - Purely mechanical interlocking device - robust and not prone to malfunctions
 - No manipulations possible.

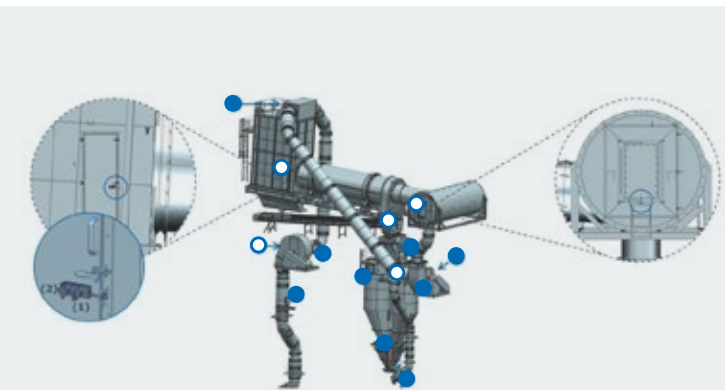

- Maintenance and service access points
- Key transfer system



Use of recycling material

The processing of recycled asphalt is a high priority when it comes to conserving natural resources. This fundamental drive for reusing materials is only one of many.

Asphalt is one of the few products that can be fully re-used. Recycling does not generate any waste. Country-specific requirements, the reduction of emissions and increased economic efficiency are points in favour of recycling and environmentally friendly asphalt production, because green asphalt is possible only with the use of recycling material. Reducing the greenhouse gas CO₂ with the concept of the hot-gas generator is a fundamental step in the overall balance of road construction technology.

Advantages of using recycling material

- > Conserving natural resources (mineral/bitumen)
- > Highest possible reuse based on the recycling concept
- > Reducing CO₂ emissions in the entire process chain: Use of RAP material from the environment of the plant, short travel distances, production of mineral (quarrying/breaking) and bitumen (refinery) are no longer required.
- > Proactive reaction to bitumen availability
- > Increased economic efficiency



Retrofit of a hot-gas generator
on an existing plant



BENNINGHOVEN



BENNINGHOVEN
Branch of Wirtgen Mineral
Technologies GmbH

Benninghovenstraße 1
54516 Wittlich
Germany

T: +49 6571 6978 0
M: info@benninghoven.com

 www.benninghoven.com